

GARABATOS → FREECAD vía ChatGPT-5

Aprende a convertir tus esquemas
en papel a diseño paramétrico real

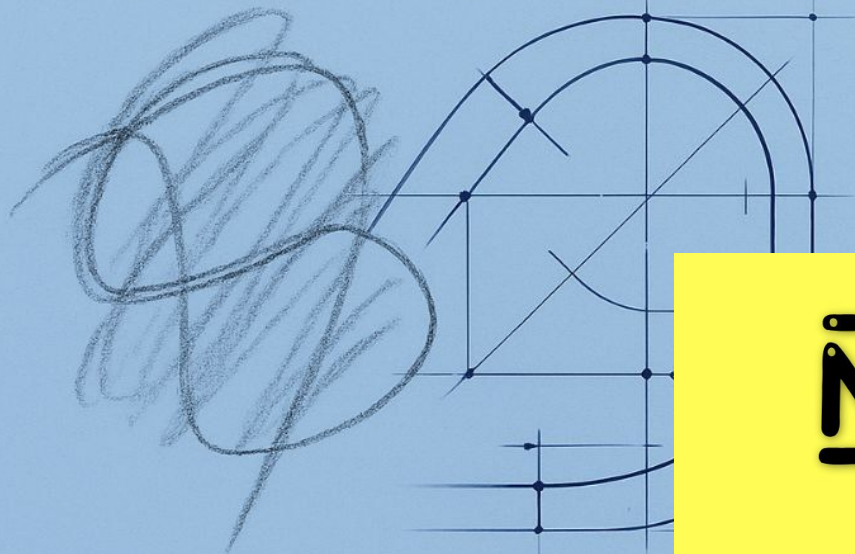

22 noviembre 2025

MAKESPACE
MADRID

- **Bienvenida a MakeSpace Madrid (Javi, 15min)**
- **Intro a Vibe3D y demo/how to (15min)**
- **Experimentos en Freecad.ai (15min)**
- **Cada uno experimenta (30min)**
- **Debate conclusiones (30min)**
- **Tour del taller (YNK)**



Lvl 15

luisriverag
@luisriverag

↓ 275 ❤️ 30

2 followers 5 following



Proficient







Skilled



Red Dwarf

+ Follow

Message

Name	Published	Likes	Downloads	Views	Makes	Remixes	In collections
 Arzopa A1 Gamut vertical stand	August 24, 2022	3	92	1,195	-	1	9
 Arzopa A1 Gamut tilted stand	January 16, 2025	5	28	177	-	-	3
 Mac book pro USB-C coupler with square USB-C	January 5, 2023	4	27	273	-	-	4
 Xiaomi Amazfit GTS protector	September 18, 2022	1	19	265	-	-	2
 Lilygo meshtastic T-deck screw/zip holder	September 5, 2025	4	17	187	-	-	10

Xiaomi IP camera VESA mount
June 14, 2022

Casi 200 descargas 🕶️ 😬 🙅🏻



luisriverag

- 🏠 Home
- 🍏 Classes
- 🗄️ Designs
- 📁 Collections
- 🎓 Tutorials
- 🚩 Challenges

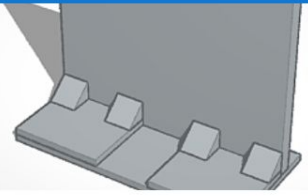

Sony Bluetooth Speaker 24inch Mo...
5 years ago
Public



Sony Bluetooth Speaker 24inch Mo...
5 years ago
Private

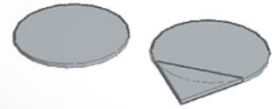

Sujeta Pegatina eco v2
5 years ago
Private



Sujeta Pegatina Circulacion para m...
5 years ago
Private

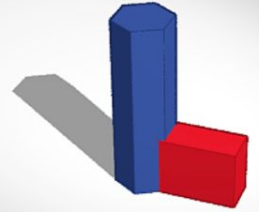

Shiny Migelo-Wluff
5 years ago
Private

Allen security key
6 years ago
Private

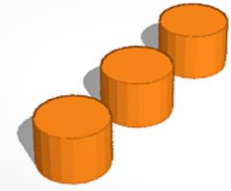

bed wheel v0.1
6 years ago
Public



Ingenious Crift-Fyrran
6 years ago
Private

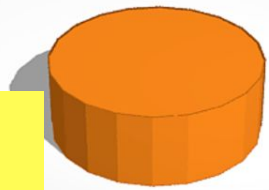

Intentando diseñar un sujeta antenas....

Frantic Blad

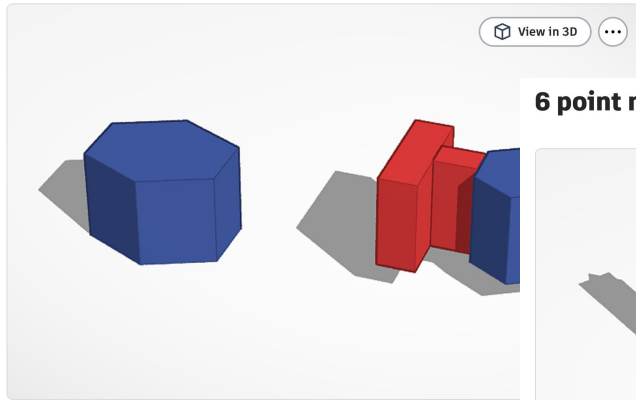

6 point mast

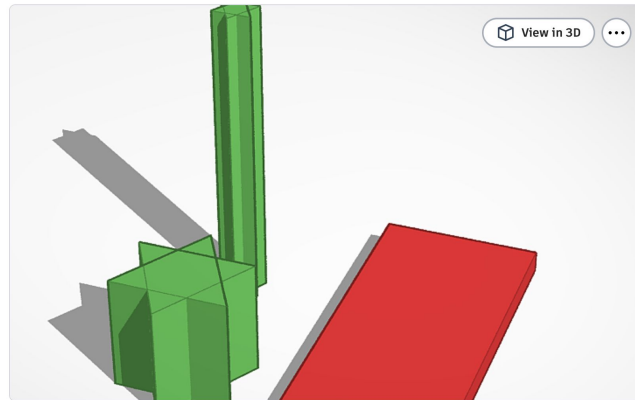

12 point mast + yagi base

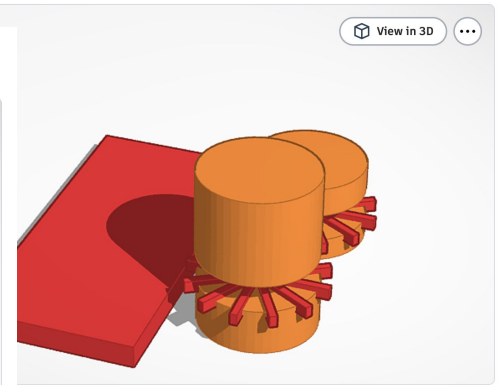

(Estaba muuuy lejos de algo fuese a resolverme el reto)

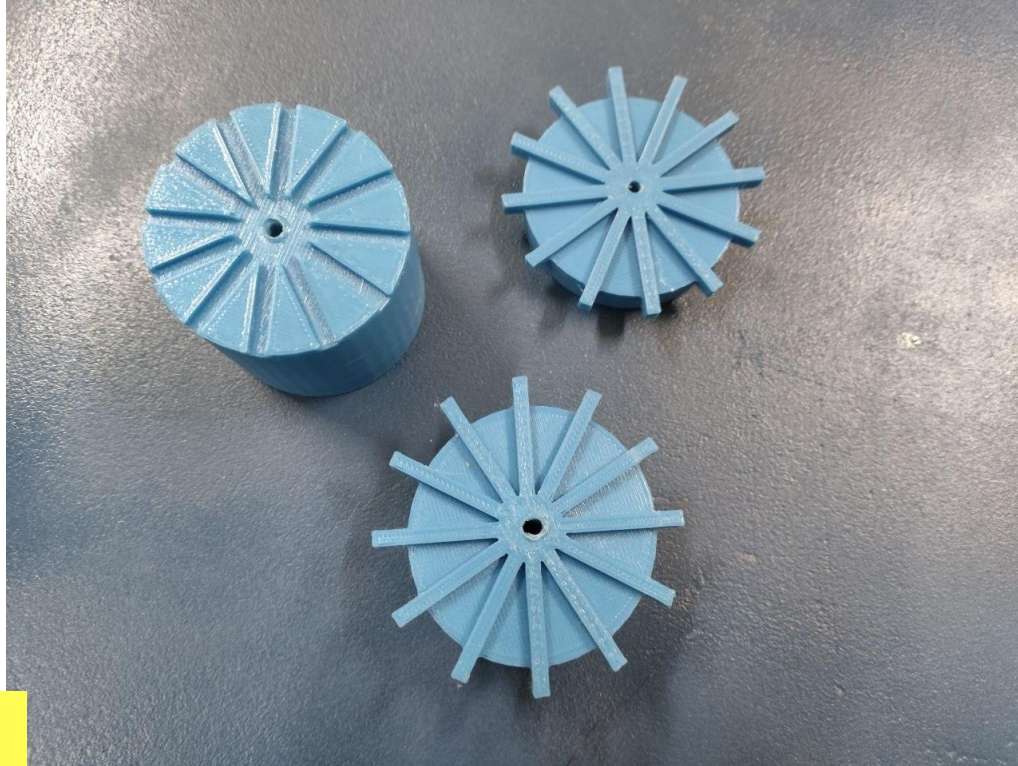

Y entonces pensé: Este prompt no va a funcionar...



Freecad model for an octagon, 60mm side, 120mm high, with attached shape on each side so I can slide attachments

python

 Copy code

```
# ==== Octagon with T-slot GROOVE (+ matching T-key slider, inverse versio
# Tested in FreeCAD 0.20-0.22 (Part workbench)

import math
import FreeCAD as App
import FreeCADGui as Gui
import Part

print("STEP 0: starting inverse version...")

# ----- Parameters (mirror your original) -----
side_len = 60.0      # mm, octagon edge
height   = 180.0     # mm, Z height

# T-slot dimensions (same numbers as your rail, but now used to create a NI
neck_width = 16.0    # along local Y (parallel to face)
neck_thick = 7.0     # depth into body from face (X)
width      = 30.0    # wider than neck (Y)
thick      = 10.0    # extra depth (down) on neck (X)
```

....pero funcionó 🤖🤖🤖

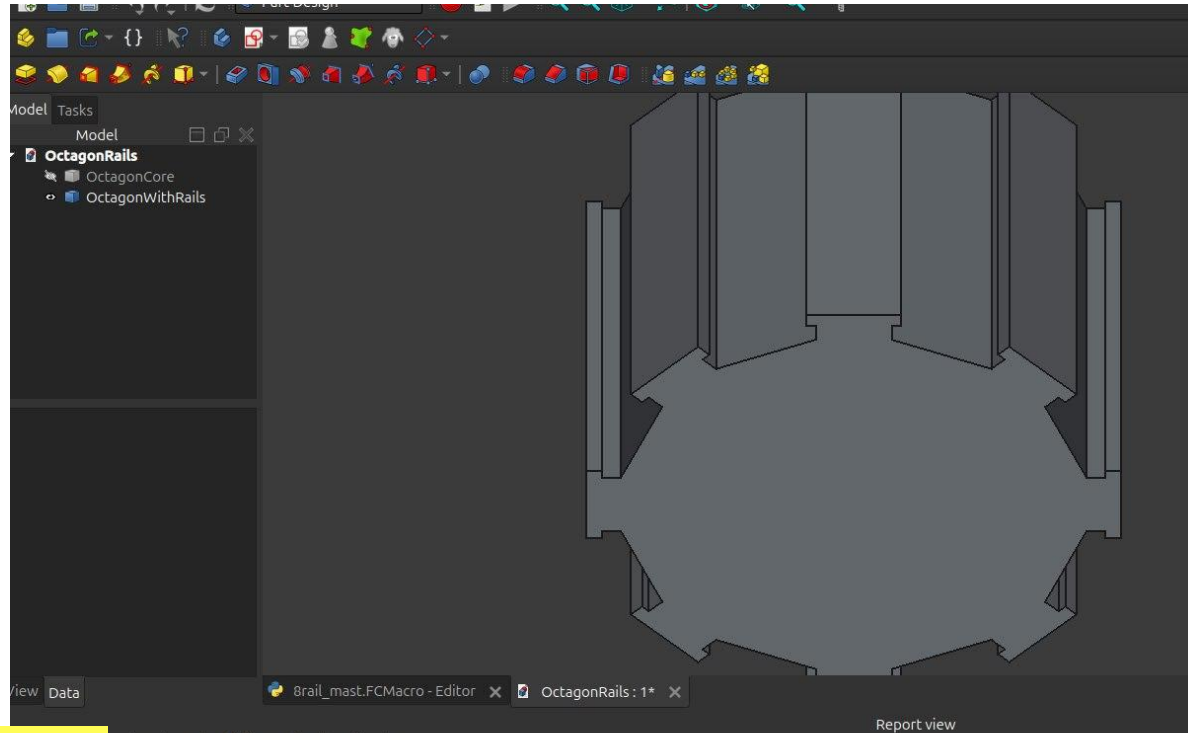

Tengo pruebas 🤔🤔🤔



¿Cuál es el límite?

Las piedras del 5º Elemento

code for freecad macro to
generate the 4 stones from
the 5th element

update it so its way more
detailed

<https://chatgpt.com/c/6913128f-8e60-832d-a08e-ac5a85681d44>

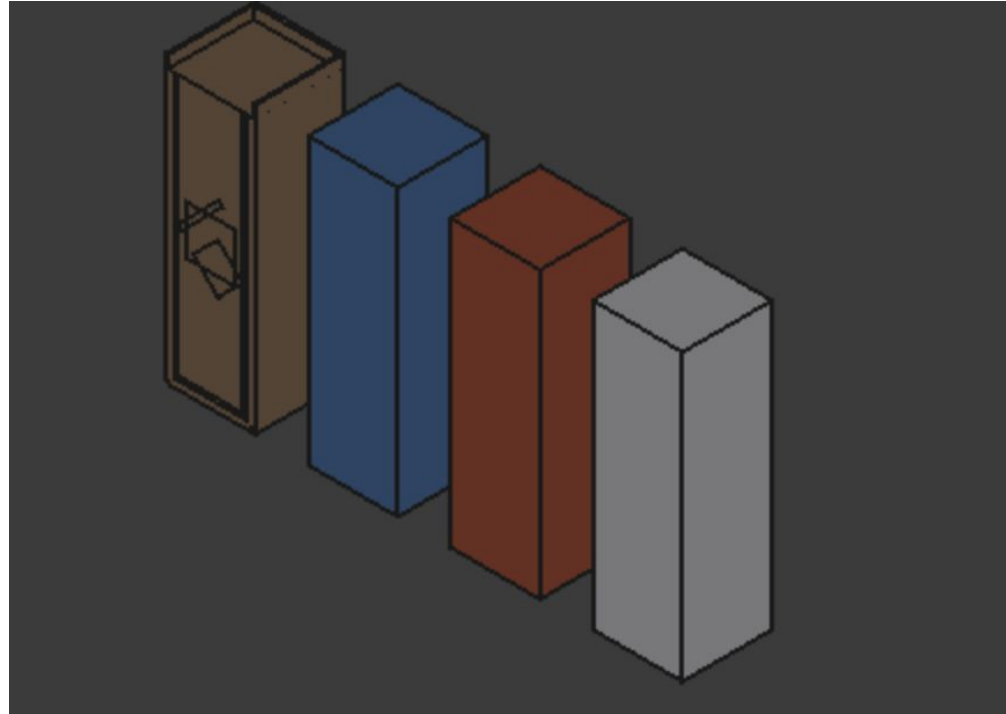

```
# -*- coding: utf-8 -*-
# FreeCAD macro: Elemental Stones (detailed, robust water) — inspired by "The Fifth Element"
# FreeCAD 0.20+/0.21+ — Part workbench API only.
#
# Changelog:
# - Water grooves: now computed via shape.common() with a safe fallback to rectangular grooves.
# This prevents "Bnd_Box is void" from null intersections on some kernels/param combos.
import FreeCAD as App
import FreeCADGui as Gui
import Part
import math
# =====
# ===== PARAMETERS =====
# =====
P = dict(
    # Stone body
    STONE_W = 44.0,    # width (X)
    STONE_D = 44.0,    # depth (Y)
    STONE_H = 140.0,   # height (Z)
    BEVEL = 2.0,       # pseudo-chamfer via triangular cuts on the 4 vertical edges
    # Layout
    GAP = 26.0,        # spacing along X between stones
    FLOOR_Z = 0.0,     # bottom Z
    # Front face frame (stepped recess)
    FRAME_MARGIN = 4.0, # border margin from all edges
    FRAME_DEPTH_1 = 1.8, # first step depth
    FRAME_DEPTH_2 = 3.6, # second step depth (added on top of step 1)
    FRAME_STEP_GAP = 2.0, # offset between steps inwards
    # General engraving depth
```

Redmi Watch 5

Freecad macro for Redmi
Watch 5



<https://chatgpt.com/c/690baf2c-89bc-8332-8698-636dc819c5f1>

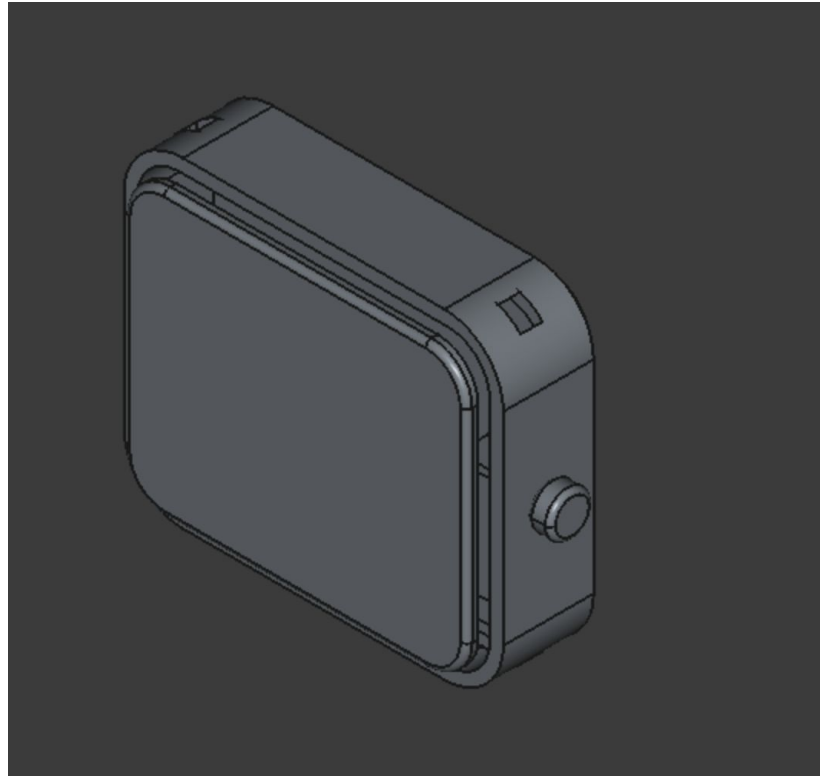

```
# -*- coding: utf-8 -*-
# Apple Watch–style parametric placeholder (Series / Ultra presets)
# FreeCAD 0.20+ (Part). Spreadsheet-free. FIXED: treat SizeModel as string.
import FreeCAD as App
import FreeCADGui as Gui
import Part
DOC = "AppleWatch_Kit"
# ---- Presets (approx outer body dims; tweak as needed) ----
PRESETS = {
    "Series_45": {"L": 45.0, "W": 38.0, "T": 10.7},
    "Series_41": {"L": 41.0, "W": 35.0, "T": 10.7},
    "Ultra_49": {"L": 49.0, "W": 44.0, "T": 14.4},
}
# ---- Defaults ----
DEFAULTS = {
    "UsePreset": 1,          # 1=use SizeModel preset; 0=manual L/W/T
    "SizeModel": "Series_45", # string; handled separately
    # Manual envelope (used if UsePreset=0)
    "L": 45.0, "W": 38.0, "T": 10.7,
    # Body styling
    "CornerR": 7.0, "SideFillet": 0.8, "Wall": 1.6,
    # Face rim (two-stage taper)
    "RimH1": 0.7, "RimH2": 1.6,
    "RimInsetTop": 1.2, "RimInsetMid": 2.0, "RimInsetBot": 3.0,
    # Glass
    "GlassThk": 1.4, "GlassProud": 0.8, "GlassInset": 2.2, "GlassTopFillet": 0.7,
    # Back cover & sensor
    "BackThk": 1.2, "SensorR": 8.0, "SensorH": 1.4,
    # Controls
```

Heltec + battery case

Freecad macro for Heltec
V3 case sized to included
3.7V 1000mAh 503450
battery

<https://chatgpt.com/c/69132320-a03c-8326-b3be-359b51c4c198>

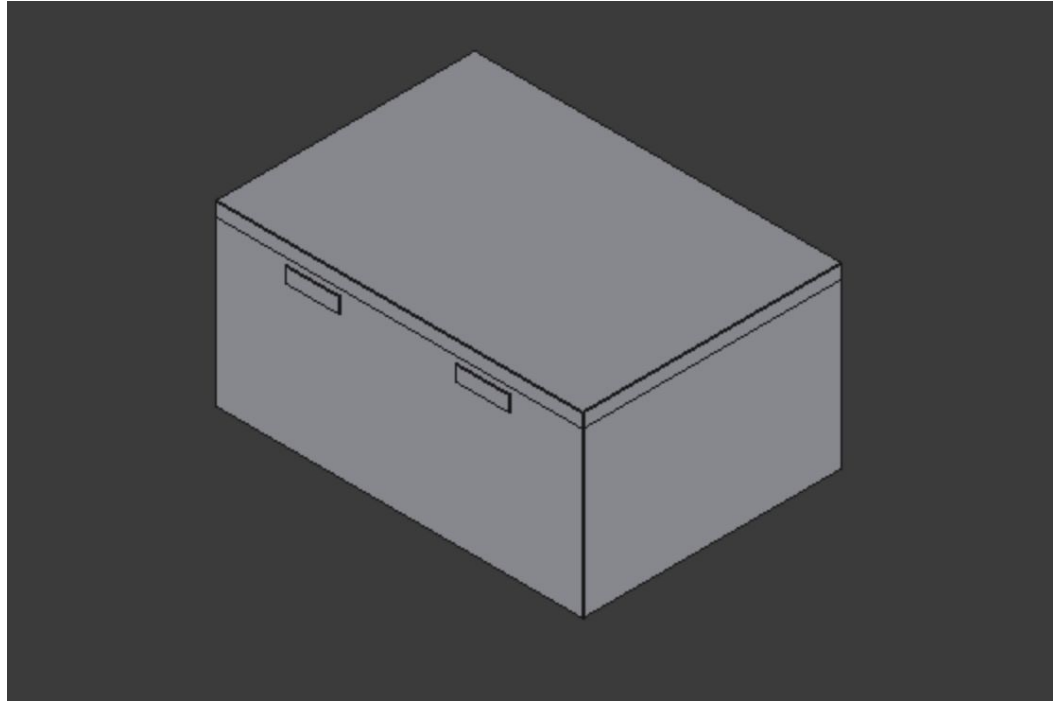

```
import FreeCAD as App
import FreeCADGui as Gui
import Part
import Draft
# -----
# Parameters (edit these safely)
# -----
# Board (Heltec WiFi LoRa 32 V3)
board_L = 50.2 # mm (length along USB-C direction) source: Heltec wiki
board_W = 25.5 # mm (width across headers)
board_H = 10.2 # mm (total assembled height incl. OLED & headers)
# Battery (503450 LiPo 1000 mAh)
bat_L = 50.0 # mm (long side)
bat_W = 34.0 # mm
bat_T = 5.0 # mm (thickness)
# Case & fit
wall = 2.0 # mm shell wall thickness
tol = 0.4 # mm manufacturing clearance
gap_board_bat = 2.0 # mm vertical air gap between battery and PCB underside
floor_thk = 2.0 # mm bottom floor thickness
lid_thk = 2.0 # mm lid thickness (flat)
lip_depth = 1.6 # mm lid/bottom overlap
lip_clear = 0.25 # mm clearance for lid lip
rib = 1.8 # mm internal ribs/tab thickness
# Standoffs under board
standoff_d = 5.0 # mm outside diameter of support posts
standoff_h = 3.0 # mm post height above battery shelf
standoff_inset = 3.0 # mm inset from PCB corners
# Optional screw bosses (use M2 self-tapping)
```

Demo



Podeis compartir vuestros experimentos en freecad.ai

FreeCAD.ai Hub

[Dashboard](#) [Logout](#)

Share AI-crafted FreeCAD ideas

Collaborate on prompts, automate repetitive work with macros, and exchange printable STL files tailored for the FreeCAD community.

[Your dashboard](#)

Latest community uploads

Apple iWatch

by luisriverag on Nov 12, 2025

Apple iWatch (kinda)

Not yet rated

Stones from the 5th Element

by luisriverag on Nov 12, 2025

I wanted Milu, but settled for these

Not yet rated

Golden Gate Bridge

by luisriverag on Nov 12, 2025

Very basic San Francisco Golden Gate bridge

4.0 / 5 · 1 rating

Made for the FreeCAD community · Share prompts, macros, and printable designs.

FUSION 360

OPENSCAD

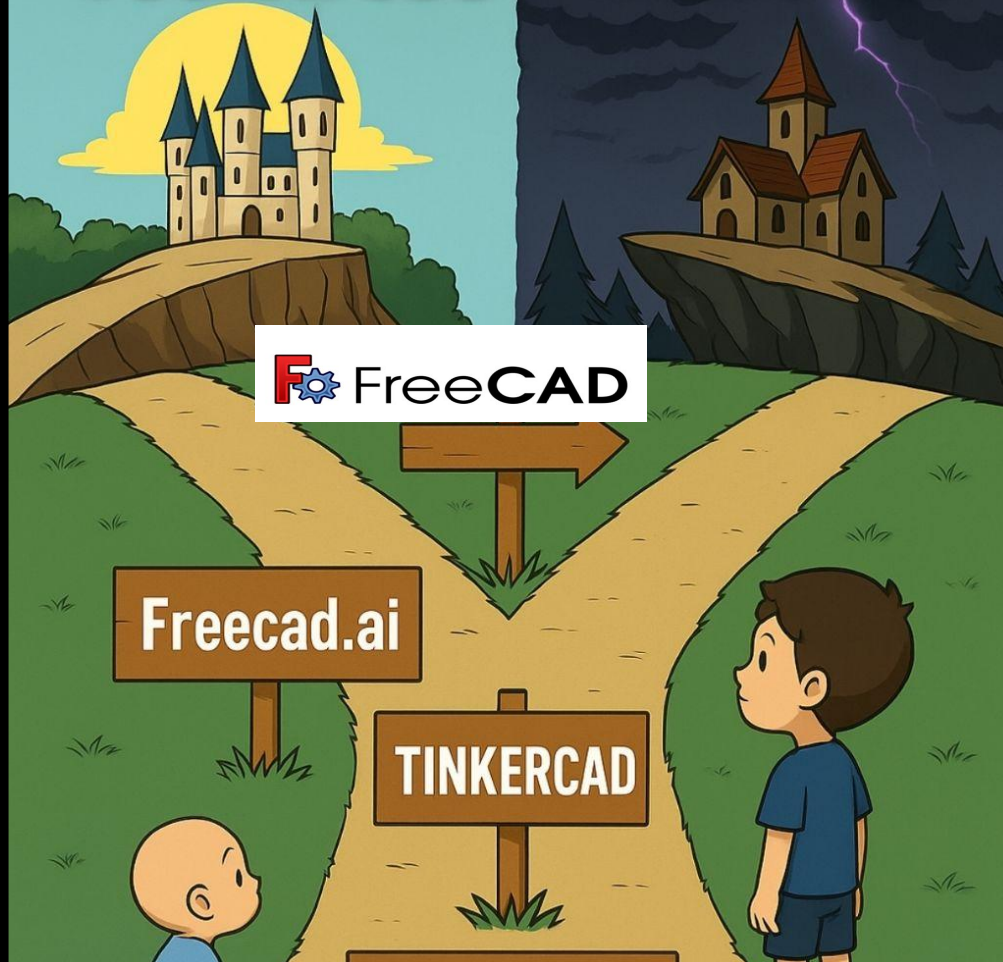

 FreeCAD

MAKESPACE
MADRID